

**INSTRUMENT APPROACH CHART-ICAO**

ATIS 127.6	119.0(125.05) AP01 (HO)
124.3(118.3) TWR01 (18R/36L)	126.1(129.0) AP02 (HO)
118.5(118.3) TWR02 (18L/36R)	120.6(125.05) AP03 (H24)
118.05(118.6) TWR03 (01/19)	119.7(129.0) AP04 (HO)
	125.50(124.70) AP08

**ZBAA BEIJING/Capital**  
VIA HUR ILS/DME RWY19

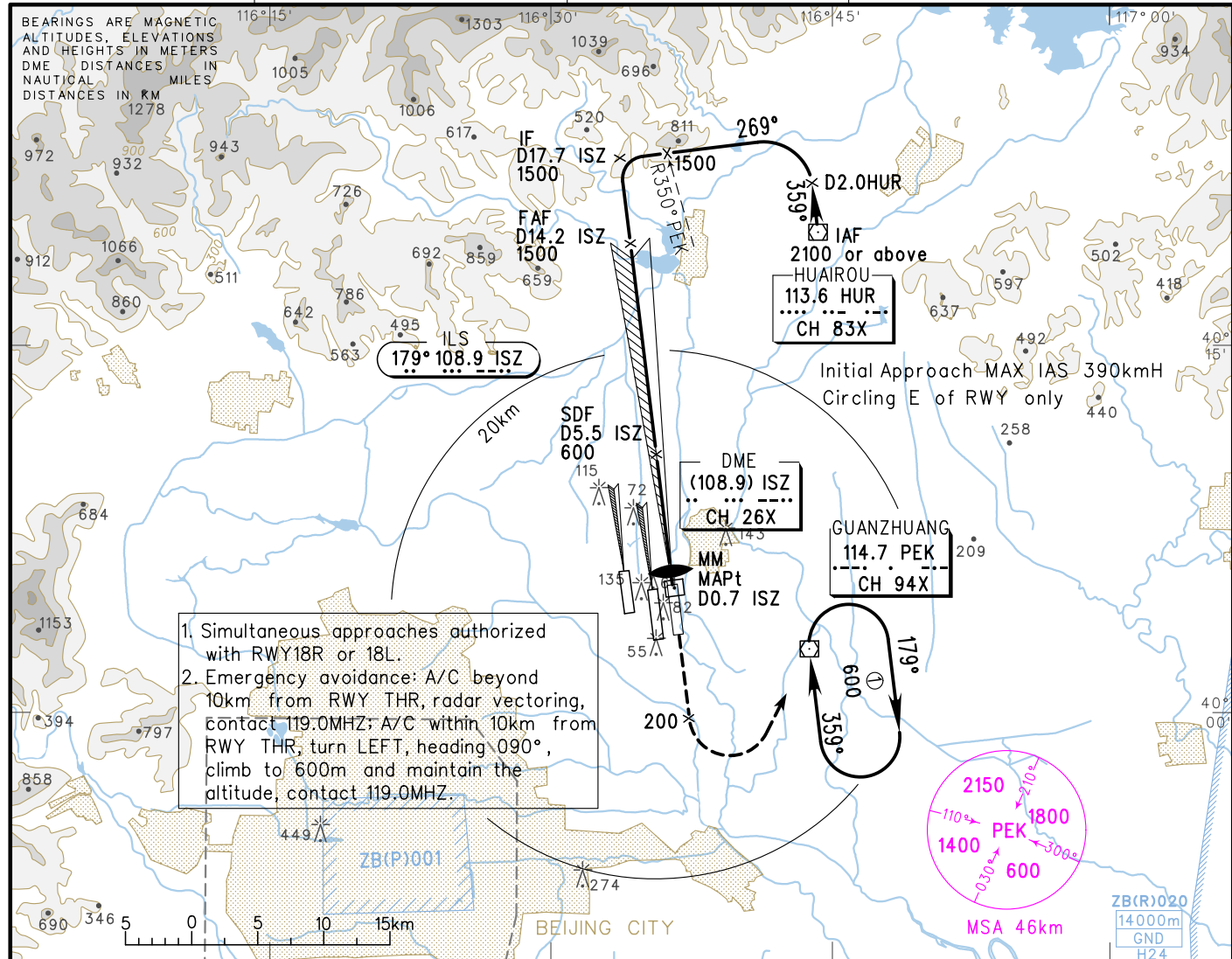

1. Simultaneous approaches authorized with RWY18R or 18L.
2. Emergency avoidance: A/C beyond 10km from RWY THR, radar vectoring, contact 119.0MHz; A/C within 10km from RWY THR, turn LEFT, heading 090°, climb to 600m and maintain the altitude, contact 119.0MHz.

GP INOP	DME (ISZ) (NM)	14	12	10	8	6	4	2
	ALT (m)		1269	1062	855	649	442	235

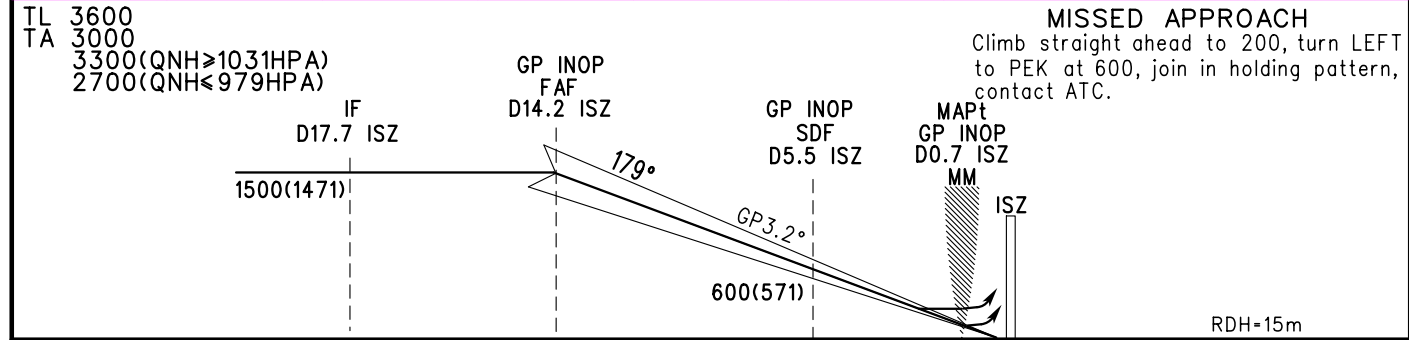

	A	B	C	D	FAF-MAPt(GP INOP) 25.05km							
ILS/DME DA(H) RVR/VIS	89(60) 550/800			89(60) 600/800	GS in kt	80	100	120	140	160	180	
					kmH	150	185	220	260	295	335	
GP INOP MDA(H) VIS	169(140) 1200	169(140) 1600	169(140) 2000		Time min:sec	10:09	08:07	06:46	05:48	05:04	04:31	
					Rate of descent m/s	2.3	2.9	3.4	4.0	4.6	5.2	
CIRCLING MDA(H) VIS	210(175) 1600	265(230) 3200	265(230) 3600		Changes: Landing minima, MSA.							