

ELEVATIONS IN METERS
ALL OTHER DIMENSIONS IN METRES

PRECISION APPROACH TERRAIN CHART - ICAO

DUBAI / International
UNITED ARAB EMIRATES
RWY 30R

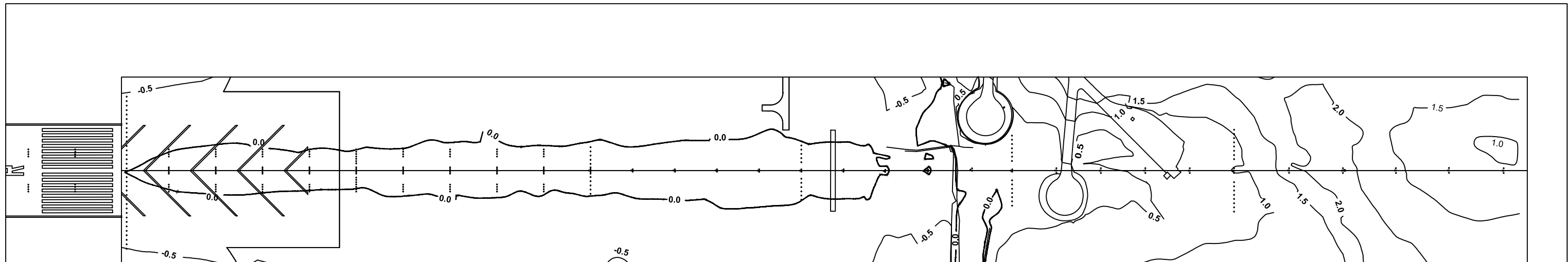

Elevation of runway threshold 9.8 M/ 32.1 FT AMSL

Maximum elevation within first
900 M of runway 9.8 M/ 32.1 FT AMSL

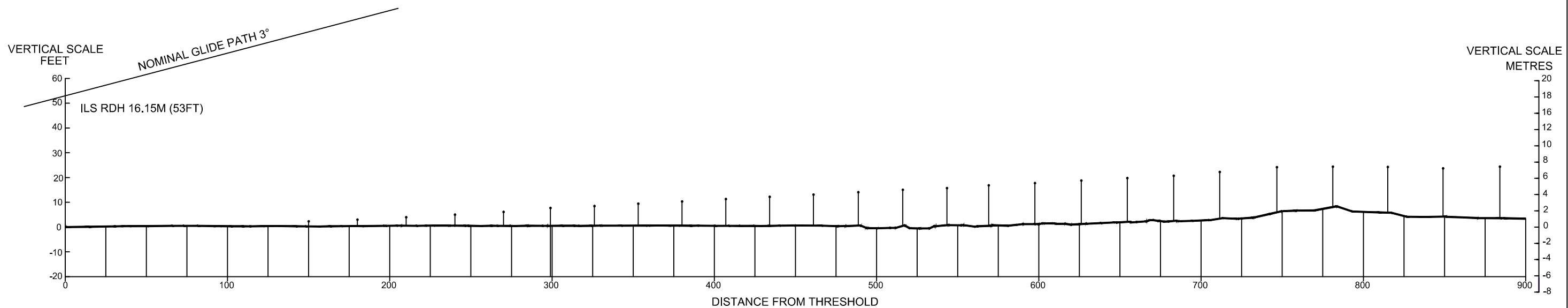

CHANGES: Revised Chart.

LEGEND	
MOBILE OBSTACLE	—
CENTRELINE PROFILE	—
APPROACH LIGHT	

HORIZONTAL SCALE 1:2500
VERTICAL SCALE 1:500
CONTOURS AND HEIGHTS ARE RELATED TO ELEVATION OF RUNWAY THRESHOLD